

SO YOU WANT TO BUILD A PHANTOM
Construction Series
 Compiled by
 Stephen G James

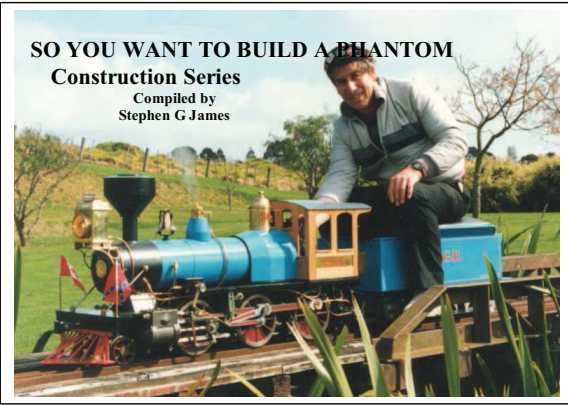

PHANTOM CONSTRUCTION
MANUAL
2-6-0 Mogul
 designed by Dave Giles

HELPFUL CONSTRUCTION IDEAS
PLANS – PHOTOS

Compiled by
 Stephen G James
 Two Volumes

Instruction & Photos 94 pages A4 - volume 1
 Appendices: 67 Plans and drawings etc A4 - volume 2
 Now Available

Printed form \$100 NZ
PDF files on CD \$25.00 NZ
Overseas postage extra (ask)
 from
S G James,
76/11 Hollister Lane
Tauranga
Ph 07 544 7177
Email steve@ontherails.com



2-6-0 7/4" Gauge Mogul designed by David Giles

Chapter 13 Boiler fittings.

Most of the boiler fittings can be purchased ready made, however they are not difficult to make from square, hexagonal and round brass bar which can be purchased quite readily.

Having said that I suggest you purchase your injectors for they are often difficult even for the experts to make.

There are many books and articles for making steam valves, Water gauges, clack valves and blow down valves that would be worth reading. While not essential a self centering four Jaw chuck is an advantage.

Turret & Steam valves:

Turret:

It is now mandatory that all steam valves are of the captured shaft type. This means they cannot be screwed out of their threads in normal use. It is usual to use stainless steel for the shaft and valve pin. The valve seat may be brass, Teflon or even an O ring. I have at various times successfully used all of these.

Components that are not silver soldered to the boiler and can be removed may be made of brass however be aware that in time brass does deteriorate with steam and becomes porous as the lead content is leached out. It is easy to machine and cutting tools work best on brass with a slightly negative rake.



A typical steam turret

Centre punch these marks and drill at these points 9/32" and tap 5/16" 32 ME. I preferred to make a flanged connector to the boiler than the 5/8" screw in fitting and seal with an "O" ring as the screw thread can allow the turret to twist if it becomes loose. If you opt for the thread I suggest a lock nut be fitted to stop the turret twisting.

(Sample page of manual)

The turret may be fabricated or a pattern made for it to be cast. The principle is the same for both. The turret is a simple manifold attached to the top rear of the boiler to supply steam to the steam valves (taps) for the various steam operated attachments.

We need to decide what we need steam to operate. Here are a few possibilities, injectors, (possibly two) steam water pump, ejector for vacuum brakes, blower for draft creation, Steam air pump, Drain cocks, whistle, and pressure gauge. It is usually good to have extra steam taps for later additions. I fitted six steam valves to my Phantoms and all but one were in use. The turret can be made by using a piece of 5/8" square brass bar. 150- 175mm long. Drill through the centre 9/32". You will probably have to drill from both ends to get right through. Thread both ends 5/16" 32 ME. On one edge mark a line down the centre and on it space evenly points 5 or 6 points 25-30mm apart for the valve positions.

this will give 5 or 6 points on the front.

Appendices A, B, C, D

- Appendix A. Phantom Plans & Drawings
- Appendix B. Quartering Broach Guide for Wheels
- Appendix C. Designing to a criteria- the evolution of a 7/4" loco
- Appendix D. Supplies and their sources.

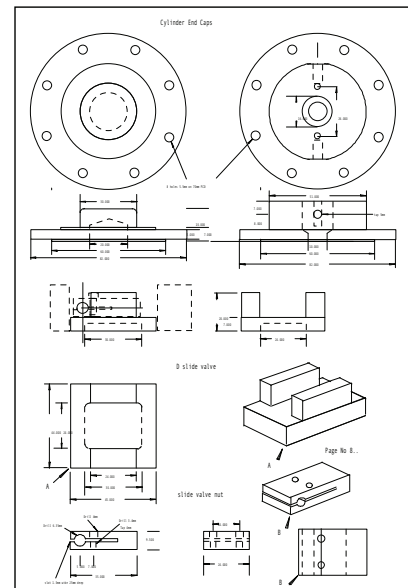

(Sample Drawing)